



TIGHTNESS CLASS



MATERIAL



BACTERIOSTATIC

Distribution Box

VCB200-16, VCB200-16/90

The Awenta PRO VCB200-16 distribution box enables the connection of up to 16 Ø75-90 mm ventilation ducts.

Ducts not in use can be closed with the supplied end caps. The box is available with a connector to the air handling unit with a diameter of Ø200 mm.

AWENTA PRO boxes are a well-thought-out design ensuring their use for many years. Thanks to their design and the use of high-quality plastics and bacteriostatic additives, they meet the expectations of the most demanding users. The range of available distribution boxes has been carefully planned to allow for their use in most typical mechanical ventilation systems.



VCB200-16

VCB200-16/90



AIR FLOW CHARACTERISTICS

VCB200-16

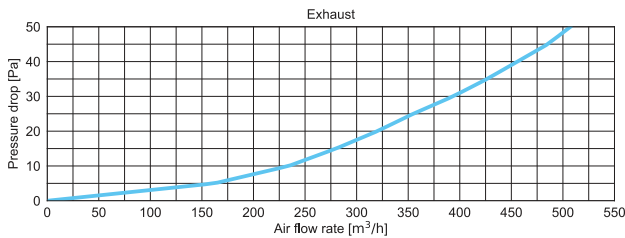
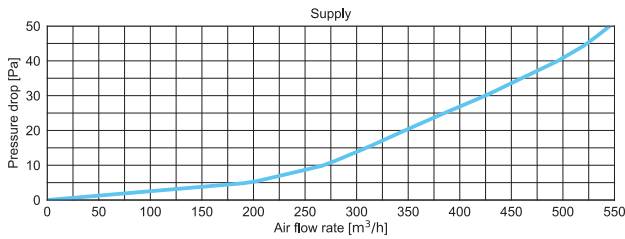

VCB200-16/90

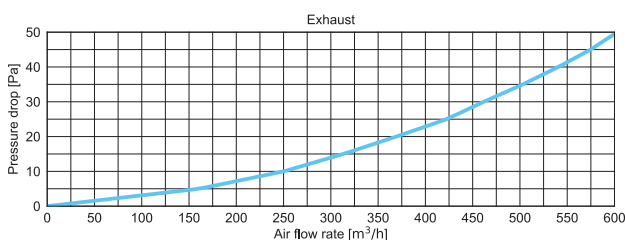
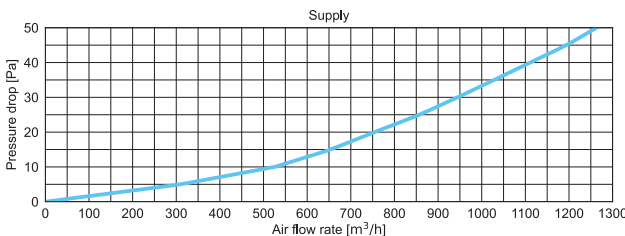

DIMENSIONS

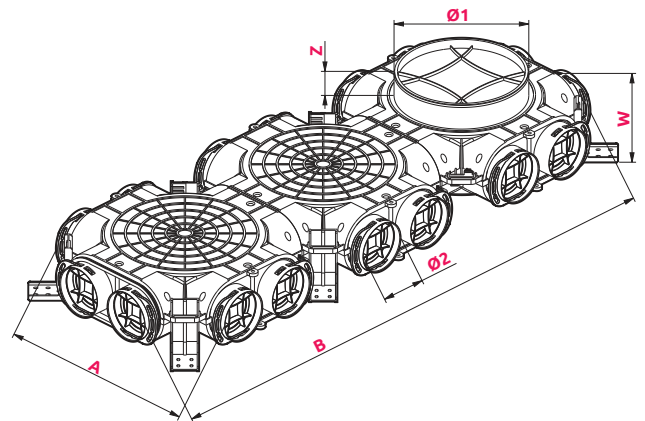

	Ø1	Ø2	A	B	W	Z
VCB200-16	200	75	347	927	104	38
VCB200-16/90	200	90	407	988	104	38

WITH **NANOSILVER** ADDITIVE
ELIMINATING UP TO 99% BACTERIA

